

## PerformArc® Robotic Welding Cells



### PerformArc® 350S Robotic Welding Cell



#### Small Footprint, High Productivity

The 350S can fit anywhere in your manufacturing plant with a small footprint just under 14 ft. x 7 ft.

Easy-to-slide teach access doors keep the system slim and allow for tight stacking.

The AC servo positioner turns 180 degree in under 2.2 seconds, minimizing index time and maximizing productivity.

#### Easy to Relocate and Set Up

Moving the 350S to a new location within your facility couldn't be easier.

Our pre-engineered system with fully-welded frame allows you to simply disconnect the utilities, relocate and reconnect.

A standard platen design with bolt and dowel holes provides repeatable fixture mounting when multiple fixtures are exchanged on the same work cell.

#### ProStar™ Fume Collector Systems

Praxair provides turnkey, integrated filtration systems for all models including overhead capture hood, ductwork package and ground based dust collector.

- Custom hoods fit all sizes and platforms
- Basic duct package includes spark arrestance
- Dust collectors for all metal types including SS with HEPA after filter capabilities
- Factory pre-wired controls
- Smoke detector with fan shutdown and fire suppression system.

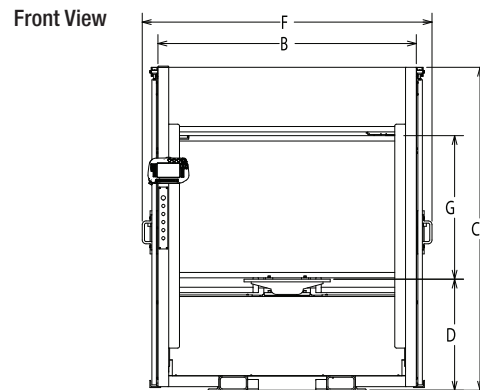
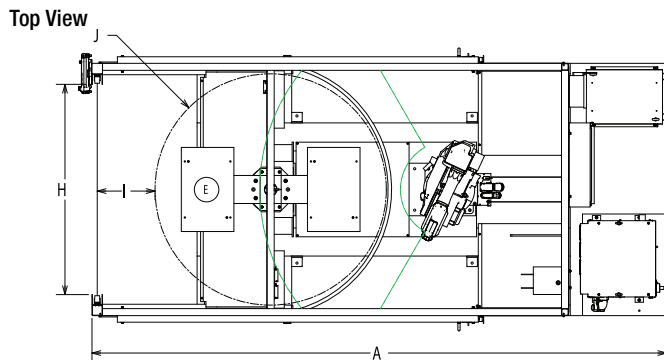

SPECIFICATIONS	PerformArc® 350S	
FRAME LENGTH	A	164 in.
FRAME WIDTH	B	72 in.
FRAME HEIGHT	C	90 in.
PLATEN HEIGHT FROM FLOOR	D	31 in.
OVERALL PLATEN SIZE	E	15 in. D 24 in. W
CELL WIDTH	F	81 in.
FIXTURE MAX ROTATION HEIGHT	G	40 in.
CELL FRONT OPENING MAX	H	60 in.
PENETRATION DISTANCE (STOPPING CALCULATION)	I	17 in.
ROTATION DIAMETER	J	66 in.
SHIPPING WEIGHT		4500 lbs.

\*Note: All dimensions are approximate.

POSITIONER GENERAL TECHNICAL SPECIFICATIONS	
MODEL	Servo Positioner
MOTOR TYPE	1.6 kW AC Digital Servo
CONTROL TYPE	Servo Control
PAYLOAD (PER SIDE)	159 kg (350 lbs.)
PAYLOAD OFFSET (FROM POSITIONER CL)	18 in.
ROTATION TIME (180 DEG. INDEX)	t < 2.2 sec.
THROUGH HOLE (FOR UTILITY PASS THROUGH)	2.16 in.

#### STANDARD FEATURES

- 6 kg arc welding robot
- 64-bit controller with TFT color display teaching pendant utilizing Windows® CE
- Auto-Continuum™ Advanced MIG Welding System
- Auto-Continuum wire drive motor assembly
- Tregaskiss™ air-cooled welding torch
- Miller designed and manufactured total productivity system

#### SYSTEM FEATURES

- Integrated operator interface (E-Stop, Auto, Servo On, Mode Select, Table Load/Unload, Start, Collision Detect, Auto Backup)
- (2) Sliding doors for easy access to the teaching area
- TCP pointer and resident TCP check program
- Tip change monitor and maintenance program for easy torch upkeep
- Arc start retry, arc overlapping, flying arc start, password protection

#### Power Source Options

Advanced MIG (GMAW)	TIG (GTAW)
Auto-Continuum™ 350A / 500A	Dynasty® 400A
TAWERS 350A / 450A	Dynasty® 800A
	BP4-300A

#### Robot Options

TM1400